

UNLESS OTHERWISE SPECIFIED: DIMENSIONS ARE IN MILLIMETERS SURFACE FINISH: TOLERANCES: LINEAR: ANGULAR:				FINISH:		DEBUR AND BREAK SHARP EDGES		DO NOT SCALE DRAWING		REVISION	
DRAWN				NAME		SIGNATURE		DATE		TITLE:	
CHK'D										Fishing Boat 17 foot GA Plan	
APPV'D											
MFG										DWG NO.	
Q.A								MATERIAL:		A3	
								WEIGHT:		SCALE:1:20	
										SHEET 1 OF 2	

1 2 3 4 5 6 7 8

A
B
C
D
E
F

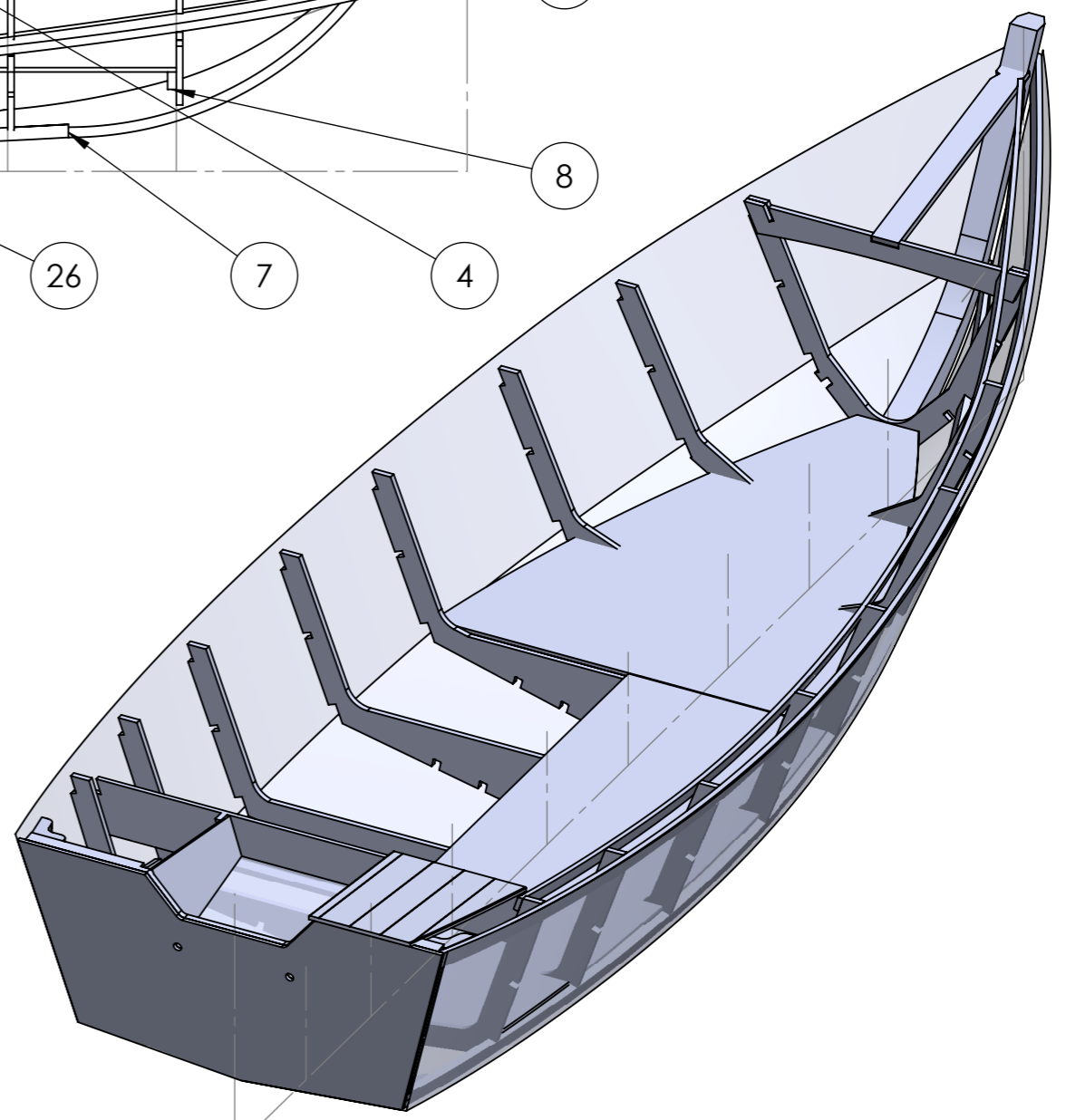
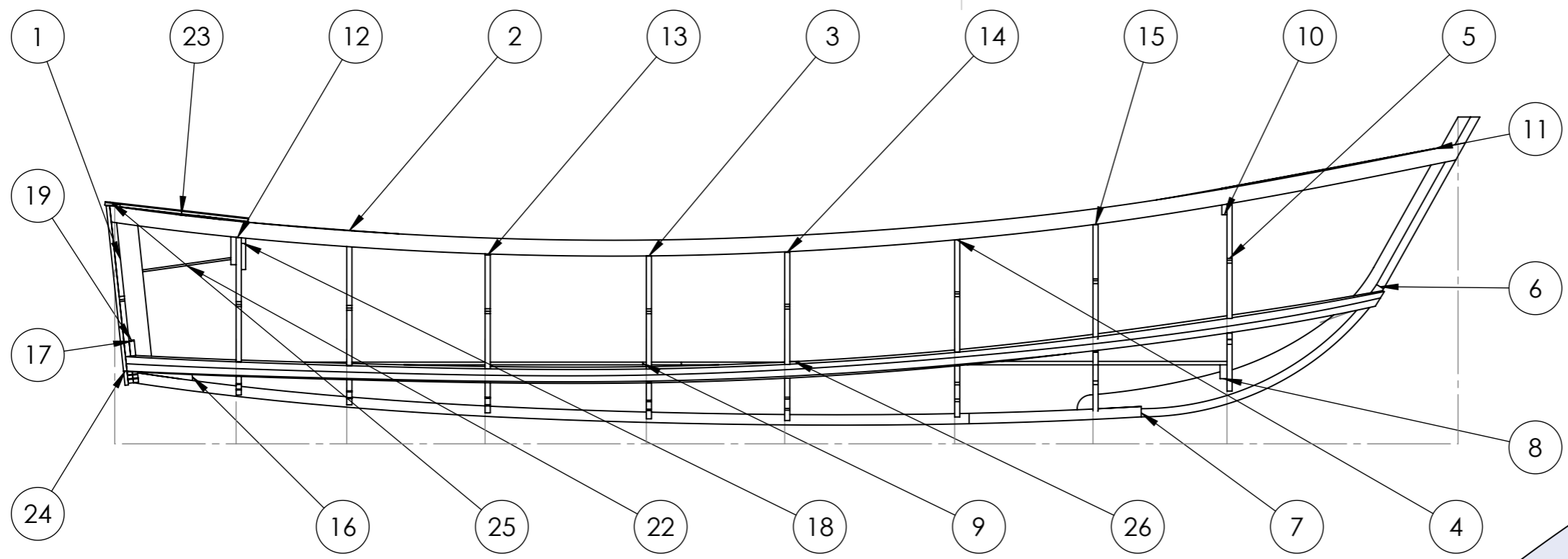

ITEM NO.	PART NUMBER	DESCRIPTION	QTY.
1	Frame 5T FB17		1
2	Frame 4 FB17		1
3	Frame 3 FB17		1
4	Frame 2 FB17		1
5	Frame 1 FB17		1
6	Stem FB 17		1
7	Keel FB 17 foot		1
8	Frame 1 block FB 17 foot		1
9	Floor FB 17 foot		1
10	Deck Beam 1A FB 17 foot		1
11	King Plank FB17		1
12	Frame 4a FB17		1
13	Frame 3a FB17		1
14	Frame 2a FB17		1
15	Frame 1a FB17		1
16	Transom lower knee FB 17		1
17	Transom Lower FB 17 foot		1
18	Well beam FB 17		1
19	Transom upright FB 17		2
20	Transom knee FB 17 foot		2
21	Transom knee mirrored FB 17 foot		2
22	Well base FB 17		1
23	Well side FB 17		2
24	Transom Outer FB 17		1
25	Rear deck pattern FB 17		1
26	Floor forw'd FB 17		1

UNLESS OTHERWISE SPECIFIED: DIMENSIONS ARE IN MILLIMETERS SURFACE FINISH: TOLERANCES: LINEAR: ANGULAR:		FINISH:	DEBUR AND BREAK SHARP EDGES	DO NOT SCALE DRAWING	REVISION
NAME	SIGNATURE	DATE		TITLE:	
DRAWN				Fishing Boat 17 foot GA Plan	
CHK'D					
APPV'D					
MFG					
Q.A			MATERIAL:	DWG NO.	A3
			WEIGHT:	SCALE:1:20	SHEET 2 OF 2